

In the course of evolution the axis of rotation of a viscoelastic sphere approaches the normal to the orbital plane and the angular velocity of the sphere approaches the orbital angular velocity.

Two small parameter k_1 and k_2 occur in (22), and $k_1 \ll k_2$. Consequently, in the rotational motion of the sphere there are two evolutions, a rapid and a slow one. The rapid and a slow one. The rapid evolution is defined by (22) with $k_1 = 0$, when only the angle φ_3 varies and the vector G describes a circular cone with axis of symmetry that coincides with the normal to the orbit. The slow evolution corresponds to terms that contain k_1 in (22) and defines the variation of the quantities I_1, I_2, I_3 .

REFERENCES

1. VIL'KE V.G., Motion of a viscoelastic sphere in a central Newtonian force field. *PMM*, Vol. 44, No.3, 1980.
2. VIL'KE V.G., Analytical and Qualitative Methods in the Dynamics of a System with an Infinite Number of Degrees of Freedom. Moscow, Izd. MGU, 1982.
3. Tides and Resonances in the Solar System. Collected papers, Ed. V.N. Zharkov, Moscow, Mir, 1976.
4. BELETSKII V.V., Motion of a Satellite Relative to the Centre of Mass in a Gravitational Field. Moscow, Izd. MGU, 1975.
5. LANDAU L.D. and LIFSHITZ E.I., Theoretical Physics. Vol.7, The Theory of Elasticity, Moscow, Nauka, 1965.
6. ANDOYER M.H., Cours de Mécanique Céleste. Paris. Gauthier-Villars. Vol.1 & 2, 1926.
7. VIL'KE V.G., On the evolution of the motion of a heavy symmetric body carrying viscoelastic rods. *Vestn. MGU, Ser. 1, Matem. Mekhan.*, No.2, 1982.
8. VIL'KE V.G., The separation of motions and the method of averaging in the mechanics of systems with an infinite number of degrees of freedom. *Vestn. MGU, Ser. Matem. Mekhan.*, No.5, 1983.

Translated by J.J.D.

PMM U.S.S.R., Vol.49, No.1, pp.24-30, 1985
Printed in Great Britain

0021-8928/85 \$10.00+0.00
© 1986 Pergamon Press Ltd.

THE PROBLEM OF THE OPTIMUM RAPID BRAKING OF AN AXISYMMETRIC SOLID ROTATING AROUND ITS CENTRE OF MASS*

M.Z. BORSHCHEVSKII and I.V. IOSLOVICH

The problem of the braking of a solid with an axisymmetric ellipsoid of inertia using three pairs of jet engines producing control moments directed along the principal axes of the ellipsoid of inertia /1-4/ is considered. The structure of the optimal trajectories is analyzed. It is shown that the four rays that lie in the plane normal to the axis of dynamic symmetry are not only the phase trajectories with special control /3/, but perform the part of main lines. The optimal trajectories reach the main lines after an infinite number of control reversals. Such trajectories which reach the main lines fill, in phase space, the outer region of two intersecting circular cones encircling the axis of dynamic symmetry.

1. Statement of the problem and formulation of the basis results. The problem of the most rapid braking of the rotation of a solid with an axisymmetric ellipsoid of inertia can be formulated as follows /1/. The system of Euler equations is given in the normal form

$$\dot{x} = b_1 u_1, \quad \dot{y} = -Dxz + b_2 u_2, \quad \dot{z} = Dxy + b_3 u_3; \quad D = (A - C) / B, \quad B = A \quad (1.1)$$

with constraints

$$|u_i| \leq 1, \quad i = 1, 2, 3 \quad (1.2)$$

where x, y, z are the projections of the vector of the instantaneous angular velocity of the solid in a moving system of coordinates attached to the principal axes of the central ellipsoid of inertia, u_i are the controls, b_i are constants, and A, B, C are the moments of inertia. It is required to transfer an arbitrary phase point of system (1.1), whose coordinates at the instant $t = 0$ are denoted by (x_0, y_0, z_0) , into the origin of coordinates in the minimum time.

**Prikl. Matem. Mekhan.*, 49, 1, 35-42, 1985

We will introduce the following new variables: the distance $r = (y^2 + z^2)^{1/2}$ of the phase point from the axis of dynamic symmetry x and the angle θ between the y axis and the projection of the radius vector of the phase point on the plane $x = 0$. From (1.1), when $r > 0$ we have the system

$$\begin{aligned} x' &= b_1 u_1, \quad r' = b_2 u_2 \cos \theta + b_3 u_3 \sin \theta \\ \theta' &= D x - b_2 \sin \theta u_2 r^{-1} + b_3 u_3 r^{-1} \cos \theta \end{aligned} \quad (1.3)$$

From the first of equations (1.3) we obtain the obvious estimate for the shortest braking time

$$T^* \geq |x_0| b_1^{-1} = T_{H1} \quad (1.4)$$

The optimal phase trajectories that attain the estimate (1.4) do not have reversals of u_1 and fill the inside of some surface, which was arbitrarily called in /1/ a "cone", and which passes through the origin of coordinates and encircles the x axis.

Inside the cone we have the non-uniqueness of the solution of the problem with respect to the controls u_2, u_3 .

The second estimate for the braking time is obtained from the second of equations (1.3) by maximizing its right side with respect to θ with condition (1.2), from which it follows that $r' \geq (b_2^2 + b_3^2)^{1/2}$ and

$$T^* \geq r_0 (b_2^2 + b_3^2)^{-1/2} = (y_0^2 + z_0^2)^{1/2} (b_2^2 + b_3^2)^{-1/2} = T_{H2} \quad (1.5)$$

The estimate (1.5) is obtained on the four rays lying in the $x = 0$ plane

$$|y| / |z| = b_2 / b_3 \quad (1.6)$$

with controls $u_1 = 0, u_2 = -\operatorname{sgn} y, u_3 = -\operatorname{sign} z$, which are particular solutions of the problem /3/.

It will be shown that the rays (1.6) are main lines and are an accumulation of reversal points. This enables us to determine the overall picture of the synthesis qualitatively, and to construct and evaluate the converging sequences of approximate solutions.

Theorem. It is possible to determine positive constants a_1, a_2, a_3 and a region Q in the coordinate space x, y, z , such that the optimal trajectory of problem (1.1), (1.2), passing through any point $M(x, y, z) \in Q$, reaches one of the rays (1.6) in a time not exceeding $a_1|x| + a_2$, and proceeds to the origin of coordinates along this ray. The region Q contains points whose coordinates satisfy the inequalities

$$(y^2 + z^2)^{1/2} (b_2^2 + b_3^2)^{-1/2} - a_1|x| - a_2 - a_3 \geq 0 \quad (1.7)$$

2. Subsidiary constructions. Let us determine the functional of "losses" I on an arbitrary trajectory that transfers the phase point $M(x, y, z)$ to the origin of coordinates for which we consider the quantity $\delta = r' + b$ ($b = \sqrt{b_2^2 + b_3^2}$).

The non-negative quantity δ defines the failure to reach the x axis at the instantaneous velocity compared with the maximum velocity possible. The functional of losses is calculated on the trajectory that transfers some point (x, y, z) to the origin of coordinates in time T as

$$I = \int_0^T \delta(t) dt = \int_0^T (r' + b) dt = -\sqrt{y^2 + z^2} + bT \quad (2.1)$$

If the point (x, y, z) is linked to the origin of coordinates by two trajectories, the functional of the losses is less on the trajectory which transfers the point to the origin of coordinates quicker, and conversely the trajectory with a smaller functional brings the point to the origin of coordinates more rapidly. This follows directly from (2.1). Thus the problem of the rapidity of action is equivalent to the problem of minimizing the functional of losses on the braking trajectory.

Fairly small values of $\delta(t)$ can be obtained only when the phase point is inside one of the two acute dihedral angles B_i ($i = 1, 2, 3, 4$) formed by the planes that cross the x axis, are symmetric about one of the rays (1.6), and make with them fairly small angles $\pm\beta$. In this case with the control

$$u_2 = -\operatorname{sgn} y, \quad u_3 = -\operatorname{sgn} z \quad (2.2)$$

we have

$$\delta \leq b(1 - \cos \beta) \quad (2.3)$$

We construct around each of the rays (1.6) a region $V_i(\beta)$ (Fig.1) bounded by the respective dihedral angle B_i and two planes $x = h$ and $x = -h$. We define the quantity h as follows:

$$h = \sqrt{b_1 \beta} / D + b \sin \beta / (DR_0) \quad (2.4)$$

where R_0 is some positive quantity.

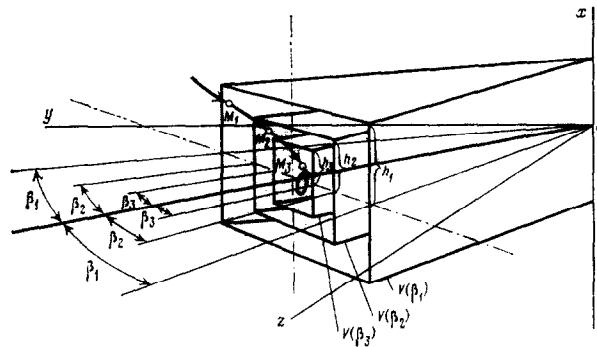

Fig. 1

Then for any number $R_0 > 0$, a fairly small $\beta_1 > 0$, can be found such that when $0 < \beta \leq \beta_1$ the following statement holds: if in some time interval $[t_-, t_+]$ the phase point of system (1.1) does not reach the region $V_i(\beta)$, and the distance of the phase point from the x axis is not less than R_0 , the integral of losses calculated in this interval satisfies the inequality

$$\int_{t_-}^{t_+} \delta(t) dt > \frac{b}{2} (1 - \cos \beta_1) (t_+ - t_- - \frac{2\sqrt{\beta_1}}{\sqrt{b_1 D}}) \quad (2.5)$$

The proof of inequality (2.5) is given in Sect. 4.

We will introduce a special trajectory L whose functional of losses will serve as the upper estimate of the functional of losses on the optimal trajectory. If (x^0, y^0, z_0) is some phase point at a fairly large distance from the x axis, then the respective special trajectory brings it to one of rays (1.6), and then brings it along that ray to the origin of coordinates. We set $u_2 = -\text{sgn } y$, $u_3 = -\text{sgn } z$ on the trajectory L . The control u_1 is defined on the first section prior to reaching the plane $x = 0$ in a time $\tau_1 = |x^0| / b_1$ as $u_1 = -\text{sgn } x^0$.

Let the radius vector of the point at which the trajectory L has reached the plane $x = 0$, make with the nearest ray (1.6) on acute angle γ . Depending on the direction in which it is necessary to turn the radius vector by the angle γ to superpose it on the ray, on the second section of trajectory L the control u_1 takes, in a certain time τ_2 , the value $+1$, and then on the third section in the same time takes the value -1 , or otherwise it takes the values $u_1 = -1$ and $u_1 = +1$ on the second and third sections, respectively.

The value of τ_2 is selected so that the phase point at the end of the third section of trajectory L reaches the ray (1.6), and the projection of its radius vector on the plane $x = 0$ is turned by an angle γ . On the fourth section the trajectory L moves along the ray to the origin of coordinates $u_1 = 0$.

3. Derivation of the basic result. The existence of optimal control in the class of integrable functions was proved in /4/ for problem (1.1), (1.2). Let L^* and L_0 be the optimal and special trajectories, issuing from point $M_0(x_0, y_0, z_0)$, and I_0^* and I_0 be the functionals of the losses calculated on these trajectories.

The estimates on which subsequent reasoning is based are obtained in Sect. 4 on the following assumptions:

- 1) the section of optimal trajectory and the special trajectory prior to reaching one of the rays (1.6) approach the x axis not closer than some arbitrary but fixed distance R_0 ;
- 2) the quantity β_1 is selected so that the following inequalities are satisfied:

$$\beta_1 \leq Db_1 R_0^2 / (100b^2), \quad \beta_1 \leq \mu/14,4$$

where μ is the minimum angle between a pair of rays (1.6).

We select some R_0 and a fairly small angle β_1 by condition 2). We set $\beta_2 = \rho\beta_1, \dots, \beta_s = \rho^{s-1}\beta_1, \rho < 1$ and construct around rays (1.6) regions $V_i(\beta_1), \dots, V_i(\beta_s)$. If in the interval $[0, t]$ the trajectory L^* runs outside region $V_i(\beta_1)$ and does not approach the x axis closer than R_0 , we have from estimate (2.5)

$$I_0 > 1/2 b (1 - \cos \beta_1) (d_1 - 2\sqrt{\beta_1} / \sqrt{bD}) \quad (3.1)$$

where d_1 is the length of the interval $[0, t]$.

Since the trajectory L^* is optimal, we have $I_0^* \leq I_0$. Taking this inequality into account, from (3.1) we obtain

$$d_1 < \bar{d}_1 = 2\sqrt{\beta_1} / \sqrt{b_1 D} + 2I_0 / |b(1 - \cos \beta_1)| \quad (3.2)$$

where \bar{d}_1 is the upper bound of d_1 and I_0 the upper bound of I_0 . The bar over a symbol, here and subsequently, indicates the upper bound. The estimate of I_0 is constructed in Sect. 4, (4.4) which depends on the initial coordinate x_0 and is independent of r_0 .

Further proof is based on upper estimates of the time intervals d_{j+1} during which the phase point moving along the optimal trajectory, crosses from region $V_i(\beta_j)$ to region $V_i(\beta_{j+1})$. It is proved that the length of the intervals d_j is majorized by a geometric progression with the denominator $\sqrt{\rho}$, where $\rho < 1$. Hence the series $\bar{d}_2 + \bar{d}_3 + \dots$ converges to a quantity that is independent of the initial point M_0 , which means that the region of values of M_0 can be selected so that the optimal trajectory reaches one of the rays (1.6) more rapidly than during the time T_{H_2} (1.5).

Let us calculate the estimate I_0 by (4.4) and \bar{d}_1 by (3.2) for some arbitrary x_0^a . We select the initial point M_0 so that

$$x_0 = x_0^a, \quad r_0 = \sqrt{y_0^2 + z_0^2} \geq R_0 + \bar{d}_1 b \quad (3.3)$$

The optimal trajectory L_0^* , issuing from that initial point, will in the course of time \bar{d}_1 be at a distance from the x axis of not less than R_0 , since b is the maximum possible velocity of approach to the x axis by the phase point. From the definition (4.4) of I_0 and condition (3.3) it follows that the time the special trajectory L_0 takes to reach one of the rays (1.6) is less than \bar{d}_1 . Hence prior to reaching a ray, the trajectory L_0 , used for comparison, is also at a distance from the x axis of not less than R_0 . Thus, if the initial point M_0 is selected by using (3.3), then conditions 1) are satisfied. Consequently the satisfaction of inequality (3.2) requires that at some instant t_1 the optimal trajectory passes through some point M_1 belonging to $V_i(\beta_1)$, and the inequality

$$t_1 \leq \bar{d}_1 \quad (3.4)$$

must be satisfied.

Let us now take some point M_j ($j = 1, \dots, s-1$), belonging to one of the regions $V_i(\beta_{j+1})$, and draw from it on optimal trajectory L_j^* and a special trajectory L_j . As previously we arrive at the inequality

$$d_{j+1} < \bar{d}_{j+1} = 2\sqrt{\beta_{j+1}} / \sqrt{b_1 D} + 2I_j / |b(1 - \cos \beta_{j+1})| \quad (3.5)$$

where d_{j+1} is the time interval during which the optimal trajectory issuing from M_j does not yet reach any of the regions $V_i(\beta_{j+1})$, and I_j is the upper estimate of the functional of losses on the special trajectory L_j (4.11), which is independent of the coordinates of the point $M_j \in V_i(\beta_j)$.

The estimate I_j is constructed in Sect. 4 so that

$$I_j > b(1 - \cos \beta_j) \tau \quad (3.6)$$

where τ is the time of motion of the phase point on the special trajectory L_j from M_j to the ray. It follows from (3.6) and (3.5) that $\tau < \bar{d}_j$. Hence, if the coordinates of M_j are such that

$$r_j = \sqrt{y_j^2 + z_j^2} \geq R_0 + \bar{d}_{j+1} b, \quad (3.7)$$

then conditions 1) are satisfied. By virtue of (3.5) some point M_{j+1} can be found on the optimal trajectory L_j^* that belongs to one of the regions $V_i(\beta_{j+1})$, and the transition time from M_j to M_{j+1} will not exceed \bar{d}_{j+1} .

We select a point M_0 such that

$$x_0 = x_0^a, \quad r_0 \geq R_0 + b \sum_{j=1}^s \bar{d}_j \quad (3.8)$$

and draw from it the optimal trajectory L^* .

Since the coordinates of M_0 satisfy condition (3.3), the phase point issuing from M_0 at instant t_0 , reaches not later than at the instant $t_0 + \bar{d}_1$ some point M_1 of one of the regions $V_i(\beta_1)$. The coordinates of M_1 evidently satisfy condition (3.7) when $j = 1$, hence the optimal trajectory will appear at point M_2 of one of the regions $V_i(\beta_2)$ not later than at the instant $t_0 + \bar{d}_1 + \bar{d}_2$. Then the optimal trajectory L^* will pass consecutively through the points of regions $V_i(\beta_j)$, until at the instant t_s it reaches the point M_s belonging to one of the regions $V_i(\beta_s)$, and

$$t_s < t_0 + \bar{d}_1 + \sum_{j=2}^s \bar{d}_j, \quad r_s > R_0 \quad (3.9)$$

We shall show that t_s is a bounded quantity as $s \rightarrow \infty$. Substituting into (3.5) the estimate of I_j from (4.11), we obtain

$$\bar{d}_{j+1} < 2\sqrt{\beta_j} \sqrt{\rho} \times (1 + c\rho^{-1/4}) / \sqrt{b_1 D}, \quad j = 1, 2, \dots; \quad c = 17 \quad (3.10)$$

Since β_j form a geometric progression with $\rho < 1$, as its denominator, the series under the summation sign in (3.9) converges. Its sum can be evaluated from above as the sum of a geometric progression with the general term (3.10). Substituting this sum and \bar{d}_1 into (3.9) we have from (3.2) and (4.4).

$$\lim_{s \rightarrow \infty} t_s = t^* < \bar{t}^* = t_0 + a_1 |x_0| + a_2 \quad (3.11)$$

$$a_1 = \frac{2}{b_1(1 - \cos \beta_1)}, \quad a_2 = \frac{2(b + \sqrt{b^2 + 1/\rho} D b_1)}{D b_1 R_0 (1 - \cos \beta_1)} + \frac{\sqrt{\beta_1}(1 + c\rho^{-2})}{\sqrt{b_1 D}(1 - \sqrt{\rho})}$$

where t^* is the exact boundary of the sequence t_s , and a_1, a_2 are constants.

The conditions (3.8) for selecting the point M_0 , taking (3.11) into account can be written for any x_0 , and arbitrarily large s in the form

$$b^{-1} \sqrt{y_0^2 + z_0^2} \geq a_3 + (\bar{t}^* - t_0) = a_1 |x_0| + a_2 + a_3 \quad (3.12)$$

$$a_3 = R_0/b$$

When the coordinates of the point M_0 satisfy condition (3.12), then for any $\varepsilon > 0$ a reasonably large s can be found so that the optimal trajectory L^* , in a time d^* not exceeding

$$\bar{d}^* = \bar{t}^* - t_0 = a_1 |x_0| + a_2 \quad (3.13)$$

will be at point M_s , distant from one of the rays (1.6) by an amount smaller than ε . After the instant \bar{t}^* and up to the instant of arrival at the origin of coordinates, the segment of the optimal trajectory of length exceeding R_0 coincides with the ray. The basic theorem is completely proved.

Consider the optimal solutions reaching the ray from the point of view of the necessary conditions of the optimality of the maximum principle.

We introduce the inverse time τ so as to have the phase point at instant $\tau = 0$ at the origin of coordinates. Denoting differentiation with respect to τ by a prime, we will write the basic and the ancilliary equation of system (1.1) in the form

$$\begin{aligned} x' &= -b_1 u_1, & y' &= D x z - b_2 u_2 \\ z' &= -D x y - b_3 u_3 \\ \lambda_x' &= -D z \lambda_y + D y \lambda_z, \\ \lambda_y' &= D x \lambda_z, & \lambda_z' &= -D x \lambda_y \end{aligned} \quad (3.14)$$

and the Hamiltonian

$$H = -\lambda_x b_1 u_1 + \lambda_y (D x z - b_2 u_2) + \lambda_z (-D x y - b_3 u_3) \quad (3.15)$$

On the segment of the trajectory lying on one of the rays (1.6) and adjoining the origin of coordinates, the conditions

$$\begin{aligned} x = 0, & \quad u_1 = 0, & \lambda_x = 0, & \quad \lambda_x' = 0 \\ u_2 = -\text{sgn } y, & \quad u_3 = -\text{sgn } z \end{aligned} \quad (3.16)$$

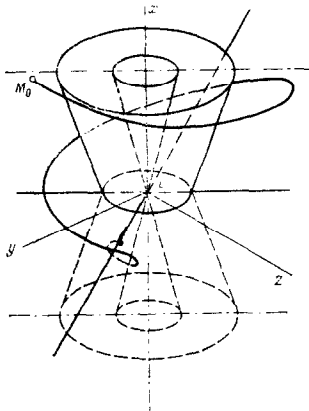

Fig. 2

must be satisfied.

The analysis of relations (3.14)–(3.16) shows that there cannot be a section of optimal trajectory with continuous control of finite length, at the end of which the trajectory reaches a ray /4/. Indeed, suppose that in the reverse motion at the instant when the phase point is on a ray and the conditions (3.16) are satisfied, for example, the positive control u_1 is switched on for a brief time Δ . Then, by virtue of (3.14), during the time $\Delta/2$ the quantities λ_x' and λ_x acquire positive values and the conditions for a maximum with respect to control is not satisfied.

Using the idea in /3/, we can show that on optimal trajectories that reach the rays (1.6) there cannot be two consecutive reversals of u_1 executed strictly on one side of the plane $x = 0$.

The optimal trajectory may be represented in the form of a helix winding on ray (1.6) (Fig. 2), whose pitch and diameter tend simultaneously to zero, and the accumulation point lies at a finite distance from the origin of coordinates. The phase point reaches the ray after an infinite number of switchings u_1 executed in a finite time. A so-called singular solution

of the second kind is obtained /5/.

With two consecutive intersections of the plane $x = 0$ by the optimal trajectory the angular distance of the phase point vector from the ray diminishes more than 17 times, if it is fairly small.

4. Estimate of losses on trajectories. On the special trajectory L , issuing from point (x, y, z) losses occur only on the first three of its sections. We have the obvious estimate

$$I \leq b [(1 - \cos \gamma_1) |x| / b_1 + 2(1 - \cos \gamma_2) \tau_2] \quad (4.1)$$

where γ_1 is the maximum acute angle in the first section between the projection of the control vector on the $x = 0$ plane and the vector $(0, -y, -z)$, and γ_2 is the similar maximum angle in the second and third sections.

By virtue of (1.3) and the control (2.2), selected on the special trajectory, we have

$$D|x| - b \sin \gamma / R_0 \leq \theta' \leq D|x| + b \sin \gamma / R_0 \quad (4.2)$$

where γ is the positive acute angle between the vectors $(0, y, z)$ and $(0, b_2, b_3)$, and R_0 is some positive quantity smaller than the minimum value of r on the first three sections of the trajectory L .

Integrating the lower estimate of θ' (4.2) on the second and third sections of trajectory L , we obtain

$$2(Db_1\tau_2^2 / 2 - b\tau_2 \sin \gamma_2 / R_0) \leq \gamma_0 \quad (4.3)$$

where γ_0 is the angle between the radius vector of the point at the beginning of the second section of trajectory L and its nearest ray (1.6).

When estimating the functional of the losses I_0 we see $\gamma_0 = \gamma_1 = \gamma_2 = \pi/2$ in (4.1) and (4.2). Then

$$I_0 \leq I_0 = b [|x_0| / b_1 + 2\bar{\tau}_2] \quad (4.4)$$

$$\bar{\tau}_2 = (b + \sqrt{b^2 + 1} \pi D b_1) / (D b_1 R_0)$$

For the estimate $I_j, j > 0$ we shall estimate more precisely the angles $\gamma_0, \gamma_1, \gamma_2$ and τ_2 . Since the point $M_j, j > 0$ belongs to one of the regions $V_i(\beta_j)$, integrating the upper estimate of θ' (4.2), we obtain on the first section

$$\gamma_0 \leq \gamma_1 \leq \beta_j + \frac{D b_1}{2} \left(\frac{h_j}{b_1} \right)^2 + b \sin \gamma_1 \frac{h_j}{b_1 R_0} \quad (4.5)$$

For further estimates it is necessary to introduce relation between R_0 and β_j . We assume

$$\beta_j \leq D b_1 R_0^2 \cdot (100b^2) \quad (4.6)$$

Substituting into (4.5) the value of h_j from (2.4) and taking into account (4.6), we obtain

$$\gamma_1 \leq C_1 \beta_j, \quad C_1 = 1,9 \quad (4.7)$$

At the beginning of the second section of L_j the angle γ may increase at the rate of $\gamma' \leq b \sin \gamma / R_0 - D|x|$ during the time $\tau \leq b \sin \gamma_2 / (R_0 D b_1)$. From this it follows that

$$\gamma_2 < \gamma_1 + (b\gamma_2)^2 / (2R_0^2 b_1 D) \quad (4.8)$$

This inequality is not satisfied when $\gamma_2 = 2\beta_j$. This can be checked by substituting estimates (4.6) and (4.7) into (4.8). Hence we have

$$\gamma_2 < C_2 \beta_j, \quad C_2 = 2 \quad (4.9)$$

From (4.3), using (4.6), (4.7) and (4.9) and the inequality $\gamma_1 > \gamma_0$, we have

$$\tau_2 < C_3 \sqrt{b_j / (D b_1)}, \quad C_3 = 0,1 C_2 + \sqrt{C_1 + 0,01 C_2} = 1,6 \quad (4.10)$$

Substituting (2.4) and estimates (4.7), (4.9), and (4.10) into (4.1), we obtain the estimate

$$I_j < C_4 b \beta_j^2 \sqrt{\beta_j} / \sqrt{D b_1}, \quad C_4 = (0,55 C_1^2 + C_2^2 C_3) = 8,4 \quad (4.11)$$

To prove inequality (2.5) we divide the interval $[t_-, t_+]$ into sections $[t_-, t^1], [t^1, t^2], \dots, [t^n, t_+]$. The quantities $t_j (j = 1, \dots, n)$ are determined consecutively as

$$t^0 = t_-, \quad t^j = t^{j-1} + \tau^j, \quad t^{n+1} = t_+$$

The quantity $\tau^j (j = 1, \dots, n+1)$ as the root of the equation $\omega_j(\beta) \tau^j = 4\beta$, where $\omega_j(\alpha)$ is defined as

$$\omega_j(\alpha) = D H_j - b \sin \alpha / R_0, \quad H_j = \max [h_1 x_{j \min}] \quad (4.12)$$

In (4.12) $x_{j \min}$ denotes the exact lower limit of $|x|$ in the interval $[t^{j-1}, t^j]$. The quantity $\omega_j(\beta)$ is the lower estimate of the angular velocity of the phase point inside of dihedral angles B when $\gamma \leq \beta$.

The number of intervals is such that $t^n + \tau^{n+1} \geq t_+$, $t^n < t_+$.

Let us estimate the integral of losses I^j on one of the segments $[t^{j-1}, t^j]$. Four cases are possible: 1) the trajectory lies on the segment outside the angles B ; 2) the trajectory passes

on the segment from the dihedral angle B on one side of plane $x=0$ into the dihedral angle B on the other side of that plane; 3) the trajectory on the segment $[t^{j-1}, t^j]$ belongs, if only partly, to only one angle B on one side of the plane $x=0$; and 4) the trajectory on this segment passes from one dihedral angle B_i to another dihedral angle B_l .

To obtain the lower estimate of I^j , we use the estimates: $\delta(t) \geq 0$ when $\gamma \leq \beta$; $\delta(t) \geq b(1 - \cos \beta)$ when $\beta < \gamma < \bar{\gamma}_j$, and $\delta(t) \geq b(1 - \cos \beta)$ when $\gamma \geq \bar{\gamma}_j$, where $\bar{\gamma}_j$ is the root of the equation $\omega_j(\gamma) = 0$. In cases 3) and 4) we use inequality (4.6), and in case 4) - the condition $\beta \leq \mu/14$, 4, where μ is the smallest angle between the rays (1.6). Summarizing the estimates I^j over all segments $[t^{j-1}, t^j]$, $j = 1, \dots, n+1$, we obtain the inequality (2.5) required.

In discussing this paper the late V.M., Alekseyev, V.I. Gurman, V.A. Egorov, and V.B. Kolmanovskii made a number of comments for which the authors are grateful.

REFERENCES

1. LEE E.B., Discussion of satellite attitude control. ARS Journal, Vol.32, No.6, 1962.
2. SMOL'NIKOV B.A., Optimal modes of braking the rotational motion of a symmetric body. PMM, Vol.28, No.4, 1964.
3. IOSLOVICH I.V., Most rapid braking of the rotation of an axially symmetric satellite. Kosmich. Issledovaniya, Vol.2, Issue 4, 1964.
4. LIE E.B. and MARKUS L., Fundamentals of the Theory of Optimal Control. Moscow, Nauka, 1972.
5. BUYAKAS V.I., Special solutions of the second kind in a problem of optimal control. Avtomatika i Telemekhanika, No.11, 1977.

Translated by J.J.D.

PMM U.S.S.R., Vol.49, No.1, pp.30-41, 1985
Printed in Great Britain

0021-8928/85 \$10.00+0.00
© 1986 Pergamon Press Ltd.

THE POINCARÉ AND POINCARÉ - CHETAYEV EQUATIONS*

L.M. MARKHASHOV

Poincaré's theory of equations in group variables /1/ has been developed by Chetayev /2/, by his students, and in a number of other investigations. Certain simple observations are made on the Poincaré and Poincaré-Chetayev (PC) equations which should be useful in the application and further study of these equations.

The equations of motion of a mechanical conservative holonomic system with independent coordinates x_1, \dots, x_s written in the form proposed by Poincaré, have the form

$$\frac{dx_i}{dt} = \xi_i^j(x) \eta_j, \quad i, j, \alpha = 1, \dots, s \quad (0.1)$$

$$\frac{d}{dt} \left(\frac{\partial L^*}{\partial \eta_i} \right) = c_{\alpha i}^j \eta_\alpha \frac{\partial L^*}{\partial \eta_j} + X_i L^* \quad (0.2)$$

Here $L^*(x, \eta)$ is the Lagrange function, η_1, \dots, η_s are the Poincaré parameters, and repeated indices denote summation. The operators

$$X_i = \xi_j^i(x) \frac{\partial}{\partial x_j} \quad (0.3)$$

form the basis of a certain s -dimensional Lie algebra which we will call algebra A

$$[X_i, X_k] = c_{ik}^\alpha X_\alpha, \quad i, k, \alpha = 1, \dots, s \quad (0.4)$$

The structural constants are skew symmetric ($c_{ik}^\alpha = -c_{ki}^\alpha$) and satisfy the Jacobi conditions

$$c_{ik}^\alpha c_{\alpha j}^\beta + c_{kj}^\alpha c_{\alpha i}^\beta + c_{ji}^\alpha c_{\alpha k}^\beta = 0 \quad (0.5)$$

It is assumed that the local group of transformations of the configurational space $\{x_1, \dots, x_s\}$ corresponding to algebra A is transitive, i.e. the following condition holds at the general position points:

$$\det (\xi_i^j(x)) \neq 0 \quad (0.6)$$

As to the rest, the operators (0.3) are arbitrary, so that for a given mechanical system

*Prikl. Matem. Mekhan., 49, 1, 43-55, 1985